

Electrical Stage Product Guide

2024/25

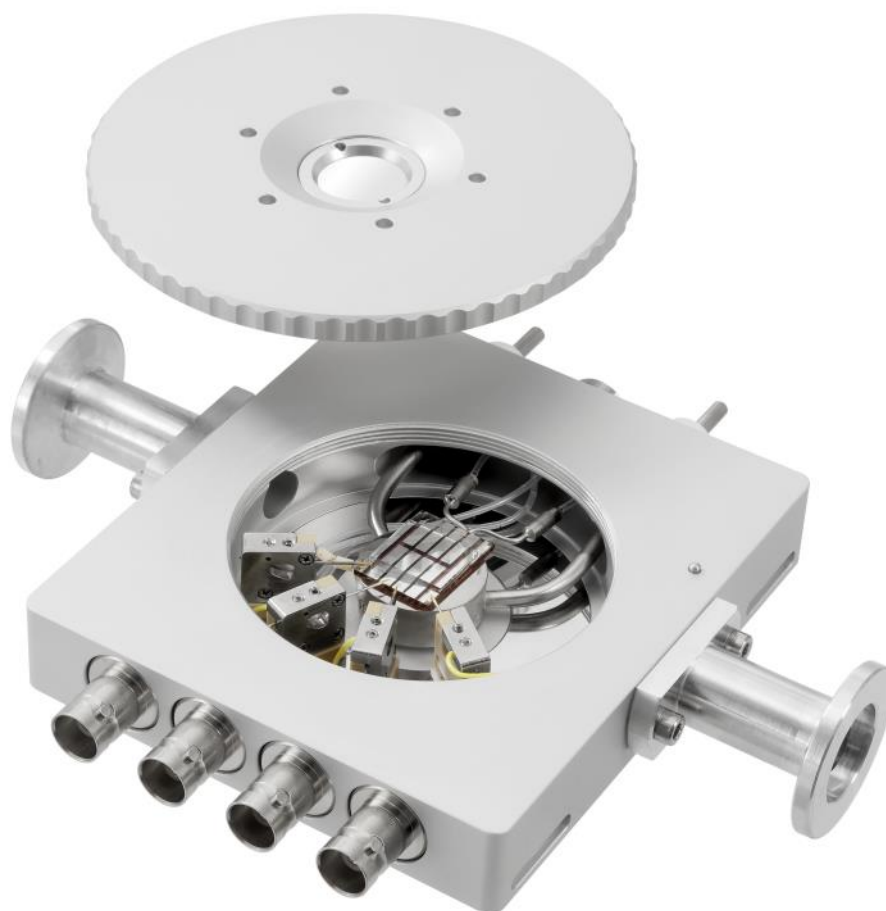

Experts in Sample Characterisation

Linkam

 www.linkam.co.uk

 +44 (0)1737 363476

 info@linkam.co.uk

 **McCRONE**
MICROSCOPES & ACCESSORIES

mccrone.com | 630-887-7100
Email: mmaorder@mccrone.com

- ◆ **Experts in Sample Characterisation for over 40 years**
- ◆ **Over 15,000 stages sold**
- ◆ **Over 40,000 citations on Google Scholar**
- ◆ **Global Distribution Network**
- ◆ **Technical and service support online, by phone and face-to-face with our team**





Contents

Why Choose Linkam?	5
System Configurator.....	6
Application Notes	8
Standard Electrical Stages	
HFS E Series (<-195 to 600°C).....	10
THMS E Series (<-195 to 600°C).....	12
LTS420 E Series (<-195 to 420°C)	14
LTS120 E Series (-40 to 120°C).....	16
TS E Series (Ambient to 1500°C).....	18
Specialised Stages	
MFS (<-195 to 600°C).....	24
Custom Stages	
Custom Stages.....	26
Software	
NEXUS.....	30
LINK.....	32
Controllers, Accessories and Microscopes	
RHGen Humidity Generator	34
Imaging Station.....	36
WCP Water Circulation Pump	39
T96 Temperature Controller	40
LNP96 Liquid Nitrogen Pump	40
Vacuum Accessories	41

World Leaders in Thermal Stages

For over 40 years Linkam has established a reputation around the world for innovation and excellence in the design and manufacture of thermal stages. With over 40000 scientific citations, and thousands more each year, our users trust Linkam to support their research in applications ranging from space to ice cream.

Delivering Quality: We go above and beyond to exceed your expectations.

Flexibility: We pride ourselves on finding tailored solutions to meet your specific needs.

Innovation: Always moving forward, we invest in creative ways to advance scientific research and discovery.

Listening: We actively listen to our customers, continuously improving our products based on their feedback.

Partnerships: We collaborate closely with our customers to find the right solutions for their needs.

Technical Support: We make our own equipment guaranteeing excellent technical support and expert advice. Linkam stages stand the test of time; Where possible, we still service stages from decades ago.



Features

Wide Temperature Range

From -195°C to 1500°C .

Accurate Temperature Sensor

The best accuracy & stability on the market.

Environmental Control

Solutions for vacuum, humidity and gas environment control.

Diverse Microscope Mounting

Stages can be mounted horizontally or vertically on virtually all microscope types.

Compatible Techniques:

Other techniques include:

Brightfield	Darkfield
Phase Contrast	DIC
Polarization	Reflected Light
Transmitted Light	

Microscopy techniques including:

Confocal	X-ray
Raman	Electrical Probe
FTIR	Vacuum
Ellipsometry	Pressure

Specialised Stages:

Tensile Testing

System Configurator — Stages

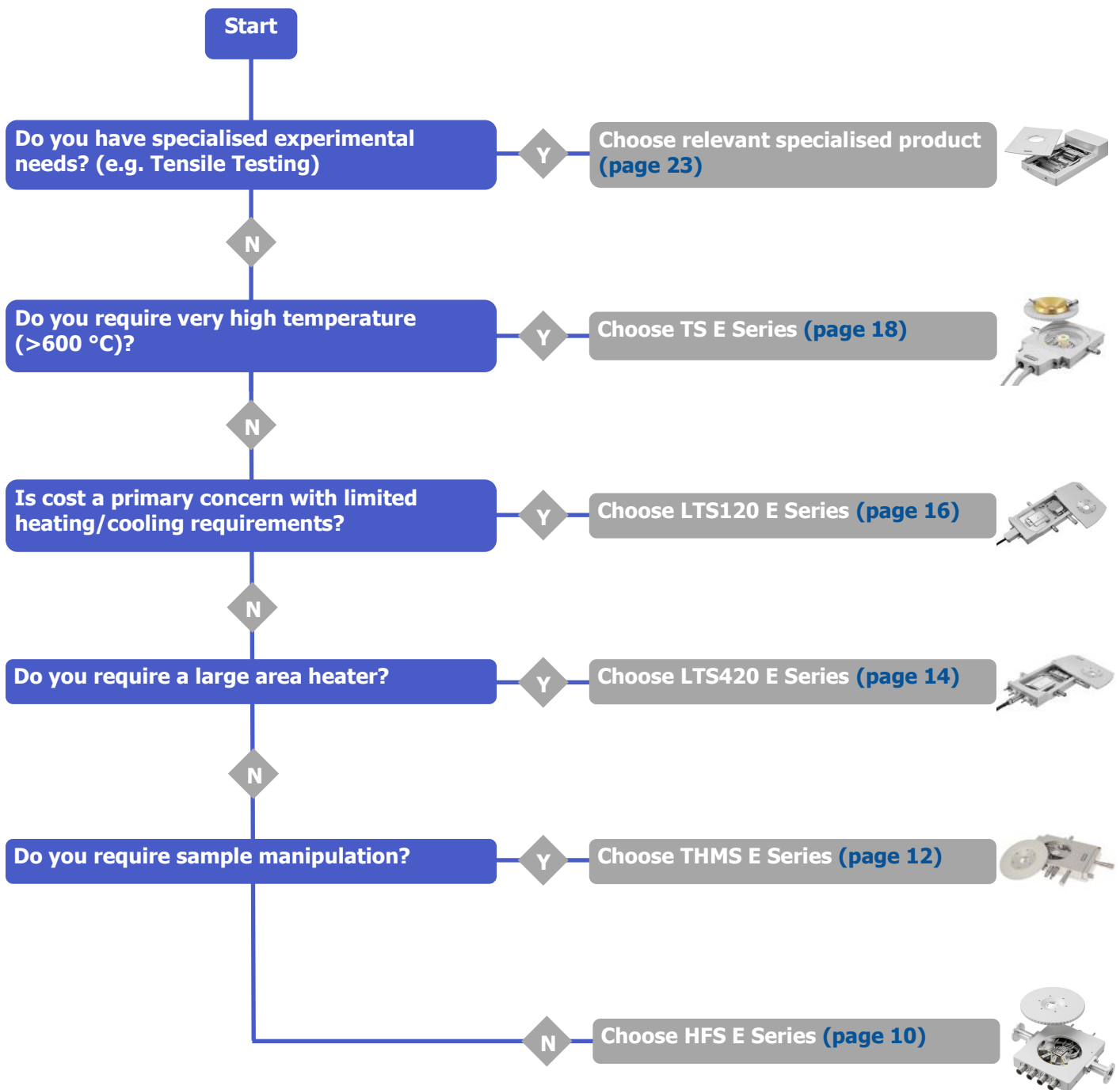

If our standard stages are not suitable for the application consult Linkam about a custom stage (page 26)

Do you have a pre-existing temperature controller?

Y

Consult Linkam for advice

N

Add T96 with either:
NEXUS/LINK Software control
LinkPad Touch screen Controller
(page 40)

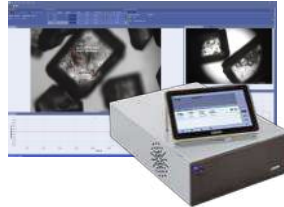

Do you require sub-ambient temperatures or fast cooling?

Y

Add LNP96 and 3L Dewar (requires compatible stage) (page 40)



Do you require humidity control?

Y

Add RHGen (requires humidity stage variant) (page 34)



Are you using an LTS120 E Series stage, or do you require temperatures above 300 °C?

Y

Add WCP (page 39)



Do you require a basic optical microscope with research grade optics

Y

Add Imaging Station (page 36)

N

Consider how to mount stage to existing system. If necessary consult with Linkam partner for mounting bracket options. Please supply as much detail as possible about your microscope!



Application Notes

Your go-to resource for cutting-edge research and insights! We publish a wide range of application notes covering a wide range of scientific fields.

These are available at: www.linkam.co.uk/applicationnotes and offer a wealth of information to researchers, engineers, and enthusiasts alike. Dive into the world of scientific discovery with Linkam's comprehensive library of application notes, some recent examples are given below.

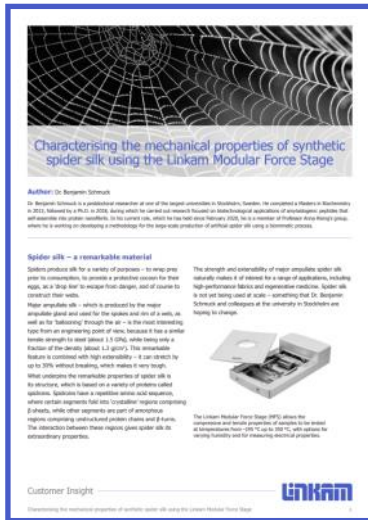

Characterising the mechanical properties of synthetic spider silk using the Linkam Modular Force Stage (MFS)

The remarkable functional properties of spider silk make it a highly interesting material for a wide range of applications, including high-performance fabrics and regenerative medicine.

The challenge in bio-engineering spider silk, however, means its potential is largely unrealised. Here, we look at how Dr. Benjamin Schmuck and his team are using a Linkam modular force stage to further our understanding of spider silk's mechanical properties and potential applications.

Learn more about:

- The challenges of producing spider silk in the lab
- Understanding its functionality using tensile testing
- The potential of spider silk as a material of the future

www.linkam.co.uk/catalogue-app1

Achieving precise temperature control in semiconductor and electronics research

With increased pressure on the electronics sector to deliver greener technology with uncompromised performance, materials research and development has stepped up to the fore.

This white paper reviews several applications at the cutting edge of semiconductor and electronics research, with a common theme of thermal and environmental control.

Learn more about:

- Organic Photovoltaics
- Crystallographic Phase Identification with SAXS/WAXS
- Ferro- and piezo-electric materials characterisation

www.linkam.co.uk/catalogue-app2



Standard Electrical Stages

Linkam has been creating sample characterisation solutions for the microelectronics and semiconductor fields for many years. Our stages enable accurate temperature control ranging from $< -195^{\circ}\text{C}$ to 1500°C . The environment can additionally be controlled to offer gas purging, controlled vacuum or humidity options.

To allow electrical and probe measurements, these stages are fitted with gold-tipped tungsten needle probes or spring-clip posts which can be coupled to various output connectors. Linkam stages are compatible with light microscopy and spectroscopy including Raman and X-ray. Electrical and probe versions are available for many of our stage types, including:

HFS E



Page 10

HFS E series stages offer a temperature range from $< -195^{\circ}\text{C}$ (with the addition of an optional LNP96-S) to 600°C , with options including probes and electrical posts, as well as vacuum, gas purging and humidity control.

THMS E



Page 12

THMS E series stages offer sample manipulation using precision ground manipulators, a temperature range from $< -195^{\circ}\text{C}$ (with the addition of an optional LNP96-S) to 600°C , with options including electrical posts, as well as vacuum, gas purging and humidity control.

LTS420 E



Page 14

LTS420 E series stages are ideal for those requiring a larger sample area, a temperature range from $< -195^{\circ}\text{C}$ (with the addition of an optional LNP96-S) to 420°C , with options including probes and electrical posts, as well as gas purging and humidity control.

LTS120 E



Page 16

LTS120 E series stages offer a larger sample area and a temperature range between -40°C (dependent upon water temperature) and 120°C without the need for liquid nitrogen, with options including probes and electrical posts.

TS E



Page 18

TS E series stages are ideal for those studying high power electronics which require extreme temperatures. They offer a temperature range from ambient to 1500°C , with options including probes and electrical posts, as well as vacuum and gas purging.

HFS E Electrical Stages

Versatile Heating and Cooling Stages



Heating and Cooling

Temperature range from < -195°C up to 600°C

Variable Heating Rates

Precise control with heating and cooling rates from 0.01°C to 150°C/min

Sample Area

22mm diameter

Optical Techniques

Supports confocal, Raman, Light Microscopy, X-ray and more

The HFS E series is used in a range of applications where rapid heating/cooling rates and high levels of accuracy and stability are required. These compact stages can be used either horizontally with microscopes, vertically in spectrometer systems, or on synchrotron beamlines. They can be fitted with a variety of window materials for Raman, IR, UV and X-ray investigations.

Samples are quickly characterised by heating to within a few degrees of the required temperature at a rate of up to 150°C/min, then slowed down to a few tenths of a degree per minute to closely examine sample changes.

NEXUS software can be used to record the entire experiment and associated images, which can then be displayed as a chart or exported for further analysis.

A system requires an HFS E series stage and a T96-S temperature controller, which is available with either NEXUS software for computer control, or a LinkPad touch screen for stand-alone control. For cooling below ambient temperatures, an optional LNP96-S liquid nitrogen pump is also available.

Features

WIDE TEMPERATURE RANGE

The temperature range spans from < -195°C (with the addition of an optional LNP96-S) up to 600°C for a versatile range of experiments. The stage body is water-cooled for work above 300°C.

RAPID HEATING RATES

The T96-S controller allows the stage to heat samples at a maximum rate of 150°C/min.

HIGH DEGREE OF ACCURACY AND STABILITY

The embedded high quality Pt100 platinum sensor guarantees high accuracy and stability throughout the temperature range.

TEMPERATURE STABILITY

< 0.01°C

QUICK-RELEASE GAS PORTS

Easy stage purging to allow atmospheric composition control.

VACUUM & HUMIDITY

Variants supporting vacuum and humidity control are available.

VARIOUS OPTICAL TECHNIQUES

Whether you need to perform Raman spectroscopy, X-ray microscopy or confocal, the HFS E series can handle it.

CUSTOM OPTIONS

Please contact us with details of your requirements.

HFS600E

Temperature range : < -195°C to 600°C

Requires LNP96-S for sub-ambient work : Yes

Sample manipulation : No

Electrical connections : 2 pin LEMO connector & posts

Vacuum compatible : No

RHGen compatible for humidity control : No

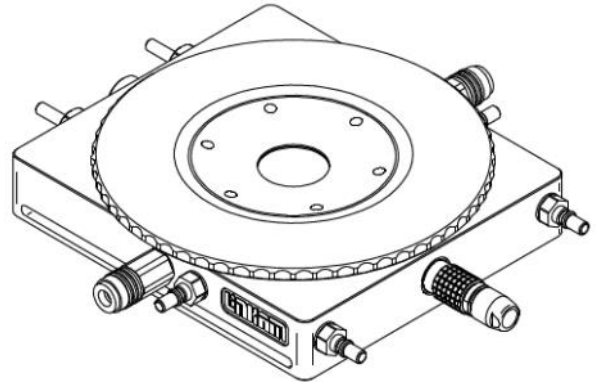

HFS600E-PB4

Temperature range : < -195°C to 600°C

Requires LNP96-S for sub-ambient work : Yes

Sample manipulation : No

Electrical connections : 4 BNC connectors & probes

Vacuum compatible : No

RHGen compatible for humidity control : No

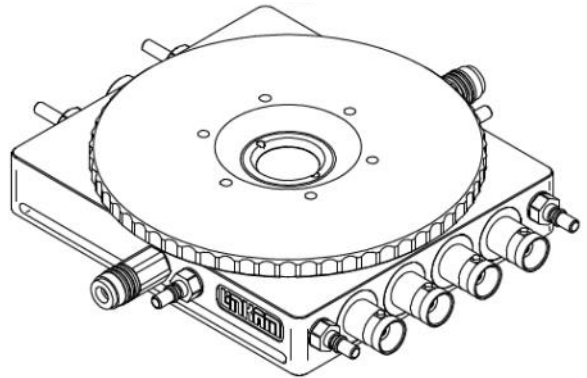

HFS350EV-PB4

Temperature range : < -195°C to 350°C

Requires LNP96-S for sub-ambient work : Yes

Sample manipulation : No

Electrical connections : 4 BNC connectors & probes

Vacuum compatible : 1×10^{-3} mBar

RHGen compatible for humidity control : No

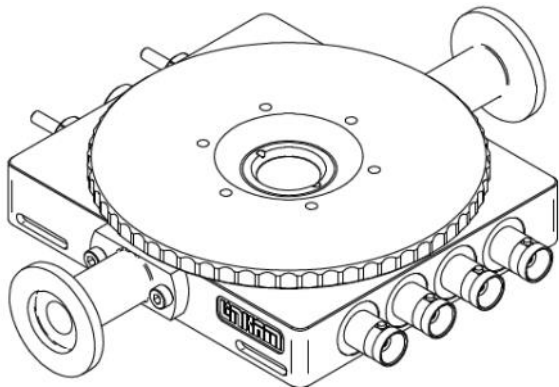

HFS600E-PB4-RH

Temperature range : < -195°C to 600°C

Requires LNP96-S for sub-ambient work : Yes

Sample manipulation : No

Electrical connections : 4 BNC connectors & probes

Vacuum compatible : No

RHGen compatible for humidity control : Yes (Ambient to 85°C)

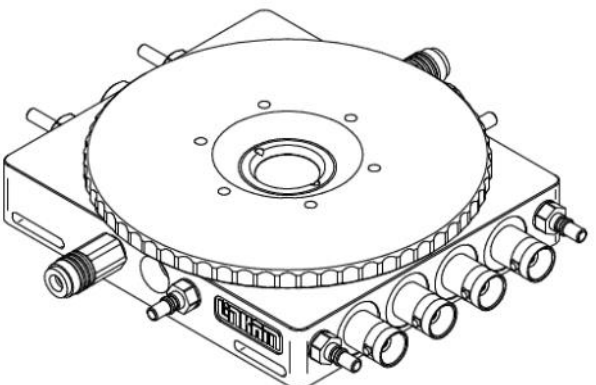

THMS E Electrical Stages

Versatile Heating and Cooling Stage



THMS600E-4

Heating and Cooling

Temperature range from
< -195°C up to 600°C

Variable Heating Rates

Precise control with heating
and cooling rates from
0.01°C to 150°C/min

Sample Area

22mm diameter

Optical Techniques

Supports confocal, Raman,
Light Microscopy, X-ray and
more

The THMS E Series is based on Linkam's market-leading THMS600 stage, one of the most widely used heating and cooling instruments available, with thousands sold around the world to date. These stages are used in a range of applications where rapid heating/cooling rates and high levels of accuracy and stability are required. Samples are quickly characterised by heating to within a few degrees of the required temperature at a rate of up to 150°C/min, then slowed down to a few tenths of a degree per minute to closely examine sample changes.

Our NEXUS software can be used to record the entire experiment and associated images, which can then be displayed as a chart or exported for further analysis.

A system requires a THMS E series stage and a T96-S temperature controller, which is available with either NEXUS software for computer control, or a LinkPad touch screen for stand-alone control. For cooling below ambient temperatures, an optional LNP96-S liquid nitrogen pump is also available.

Features

WIDE TEMPERATURE RANGE

The temperature range spans from < -195°C (with the addition of an optional LNP96-S) up to 600°C for a versatile range of experiments. The stage body is water-cooled for work above 300°C.

RAPID HEATING /COOLING RATES

The powerful T96-S controller allows the stage to heat samples at a maximum rate of 150°C/minute.

HIGH DEGREE OF ACCURACY AND STABILITY

The embedded high quality Pt100 platinum sensor guarantees high accuracy and stability throughout the temperature range.

TEMPERATURE STABILITY

< 0.01°C

QUICK-RELEASE GAS PORTS

Easy stage purging to allow atmospheric composition control.

HUMIDITY

A variant supporting humidity control is available.

XY MANIPULATORS

Control of sample position over 15mm of travel in X and Y directions via precision ground manipulators.

VARIOUS OPTICAL TECHNIQUES

Add environmental control to Raman spectroscopy, confocal microscopy, X-ray diffraction, and most other experimental setups.

CUSTOM OPTIONS

Please contact us with details of your requirements.

THMS600E

Temperature range : < -195°C to 600°C

Requires LNP96-S for sub-ambient work : Yes

Sample manipulation : Yes

Electrical connections : 2 pin LEMO connector & posts

Vacuum compatible : No

RHGen compatible for humidity control : No

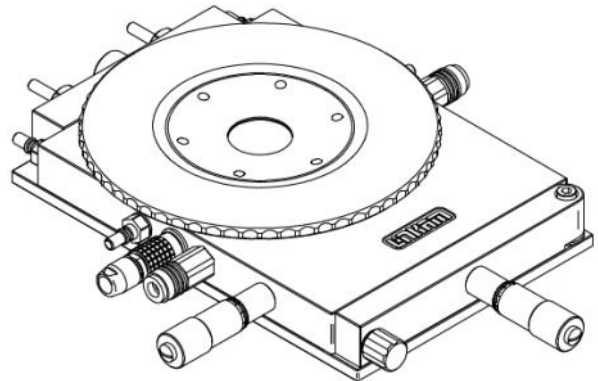

THMS350EV-4

Temperature range : < -195°C to 350°C

Requires LNP96-S for sub-ambient work : Yes

Sample manipulation : Yes

Electrical connections : 4 pin LEMO connector & posts

Vacuum compatible : 1×10^{-3} mBar

RHGen compatible for humidity control : No

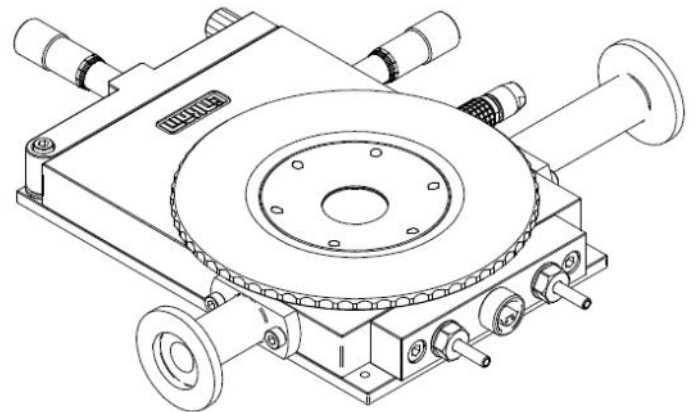

THMS600E-4-RH

Temperature range : < -195°C to 600°C

Requires LNP96-S for sub-ambient work : Yes

Sample manipulation : No

Electrical connections : 4 pin LEMO connector & posts

Vacuum compatible : No

RHGen compatible for humidity control : Yes (Ambient to 85°C)

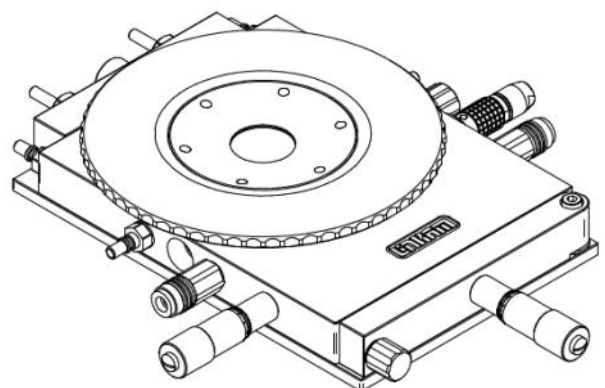

LTS420 E Electrical Stages

Optimised Isothermal Sample Analysis Stage



LTS420E-PB4

Heating and Cooling

Temperature range from
< -195°C up to 600°C

Variable Heating Rates

Precise control with heating
and cooling rates from
0.01°C to 50°C/min

Large Heating Area

Ideal for larger samples of up
to 53.5mm x 43mm

Swing-out Lid

For easier and faster sample
loading

The LTS420 E series are versatile heating and cooling stages for larger samples, where high speed heating and cooling are required alongside outstanding thermal stability. They feature a 53.5mm x 43mm silver block with a platinum resistor sensor embedded close to the surface for accurate temperature measurements.

Samples can be quickly and precisely characterised as a function of temperature or other environmental parameters, with the swing-out lid allowing easy access and fast sample changing. The sample chamber is gas tight and has valves to allow atmospheric composition control.

NEXUS software can be used to record the entire experiment and associated images, which can then be displayed as a chart or exported for further analysis.

A system requires an LTS420 E series stage and a T96-S temperature controller, which is available with either NEXUS software for computer control, or a LinkPad touch screen for stand-alone control. For cooling below ambient temperatures, an optional LNP96-S liquid nitrogen pump is also available.

Features

LARGE SILVER HEATING BLOCK

Provides excellent temperature uniformity whilst enabling high heating and cooling rates (0.01°C to 50°C/min) with rapid response times. Water-cooled stage body for work above 300°C.

HIGH DEGREE OF ACCURACY AND STABILITY

The embedded high quality Pt100 platinum sensor guarantees high accuracy and stability throughout the temperature range.

TEMPERATURE STABILITY

<0.01°C

SWING-OUT LID

The swing mechanism of the lid allows greater access and easier loading of samples.

XY MANIPULATORS

Some variants have precision ground manipulators which allow control of sample position over 15mm of travel in X and Y directions.

QUICK-RELEASE GAS PORTS

Simple stage purging to allow atmospheric composition control.

HUMIDITY

A variant supporting humidity control is available.

CUSTOM OPTIONS

Please contact us with details of your requirements.

LTS420E

Temperature range : < -195°C to 420°C

Requires LNP96-S for sub-ambient work : Yes

Sample manipulation : Yes

Electrical connections : 2 pin LEMO connector & posts

Vacuum compatible : No

RHGen compatible for humidity control : No

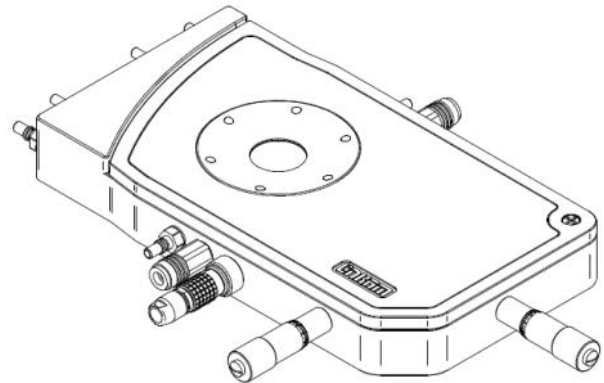

LTS420E-PL8

Temperature range : < -195°C to 420°C

Requires LNP96-S for sub-ambient work : Yes

Sample manipulation : No

Electrical connections : 2 X 4 pin LEMO connectors, probes & posts

Vacuum compatible : No

RHGen compatible for humidity control : No

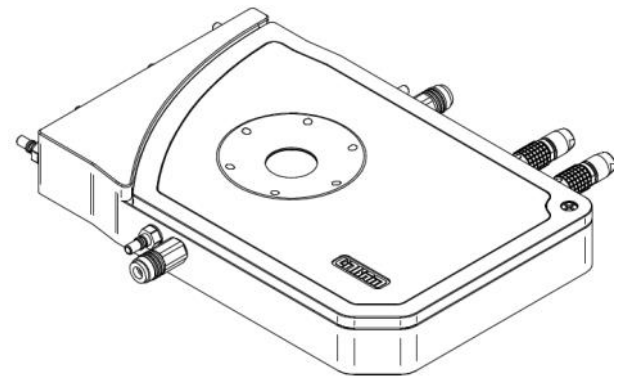

LTS420E-PB4

Temperature range : < -195°C to 420°C

Requires LNP96-S for sub-ambient work : Yes

Sample manipulation : No

Electrical connections : 4 BNC connectors & probes

Vacuum compatible : No

RHGen compatible for humidity control : No

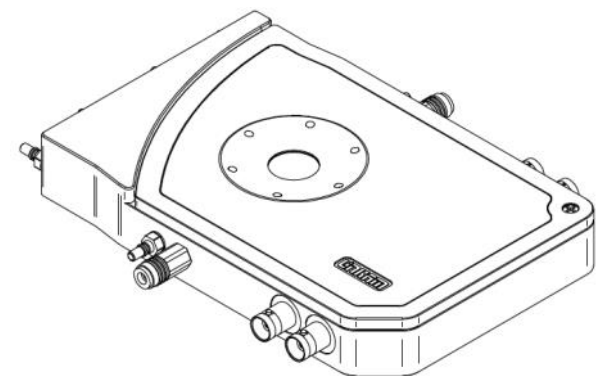

LTS420E-PB4-RH

Temperature range : < -195°C to 420°C

Requires LNP96-S for sub-ambient work : Yes

Sample manipulation : No

Electrical connections : 4 BNC connectors & probes

Vacuum compatible : No

RHGen compatible for humidity control : Yes (Ambient to 85°C)

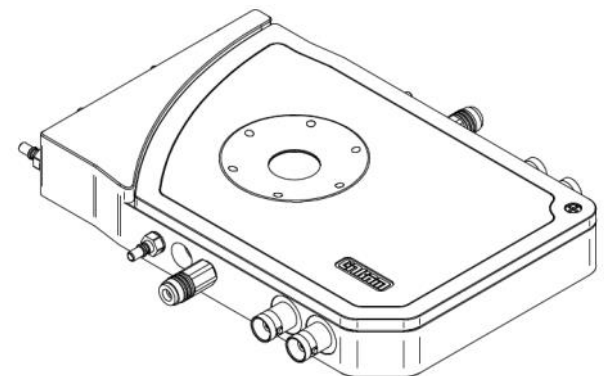

LTS120 E Electrical Stages

Optimised Isothermal Sample Analysis Stage

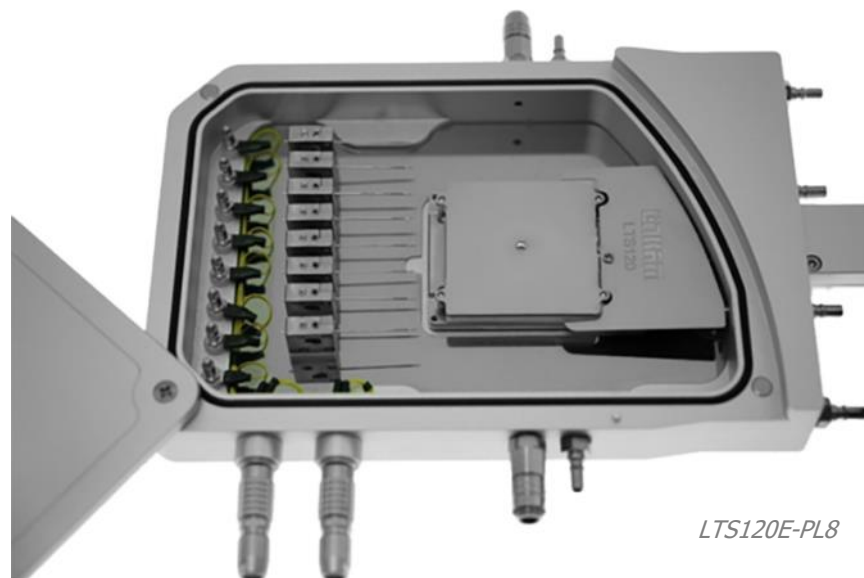

Heating and Cooling

The temperature range spans from -40°C to 120°C .

Variable Heating Rates

Precise control with heating and cooling rates from 0.01°C to $30^{\circ}\text{C}/\text{min}$

Large Heating Area

Ideal for larger samples of up to $40\text{mm} \times 40\text{mm}$

Swing-out Lid

For easier and faster sample loading

The LTS120 E series are easy-to-use thermoelectrically cooled stages which provide a straightforward means of temperature control with minimal setup required. These stages do not require liquid nitrogen to cool below ambient temperature and provide a simple turnkey solution with $\pm 0.1^{\circ}\text{C}$ temperature stability and control. The swing-out lid aids rapid sample loading and probe adjustment.

The thermoelectric heater measures $40\text{mm} \times 40\text{mm}$ and has a platinum resistor sensor embedded close to the surface for accurate temperature measurements. They have a temperature range of -40°C , (optional water cooler required for temperatures below -25°C), to 120°C .

Samples can be quickly and precisely characterised as a function of temperature or other environmental parameters, with the swing-out lid allowing easy access and fast sample changing. The sample chamber is gas tight and has valves to allow atmospheric composition control.

NEXUS software can be used to record the entire experiment and associated images, which can then be displayed as a chart or exported for further analysis.

Features

WIDE TEMPERATURE RANGE

The temperature range spans from -40°C to 120°C . (optional water cooler required for temperatures below -25°C)

HIGH DEGREE OF ACCURACY AND STABILITY

The embedded high quality Pt100 platinum sensor guarantees high accuracy and stability throughout the temperature range.

TEMPERATURE STABILITY

$< 0.1^{\circ}\text{C}$

SWING-OUT LID

The swing mechanism of the lid allows easy access and loading of samples.

XY MANIPULATORS

Some variants have precision ground manipulators which allow control of sample position over 15mm of travel in X and Y directions.

QUICK-RELEASE GAS PORTS

Simple stage purging to allow atmospheric composition control.

CUSTOM OPTIONS

Please contact us with details of your requirements.

LTS120E

Temperature range : -40°C to 120°C
(optional water cooler required for temperatures below -25°C)

Requires LNP96-S for sub-ambient work : No

Sample manipulation : Yes

Electrical connections : 2 pin LEMO connector & posts

Vacuum compatible : No

RHGen compatible for humidity control : No

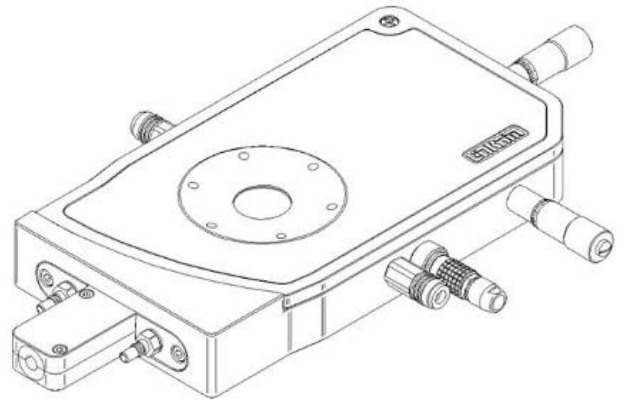

LTS120E-PL8

Temperature range : -40°C to 120°C
(optional water cooler required for temperatures below -25°C)

Requires LNP96-S for sub-ambient work : No

Sample manipulation : No

Electrical connections : 2 X 4 pin LEMO connector,
posts & probes

Vacuum compatible : No

RHGen compatible for humidity control : No

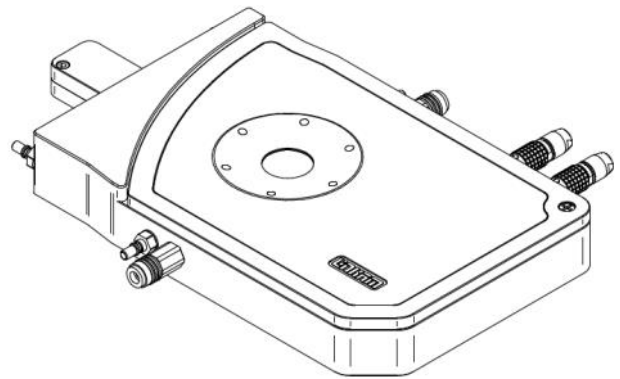

TS E Electrical Stages

High Temperature Heating Stages

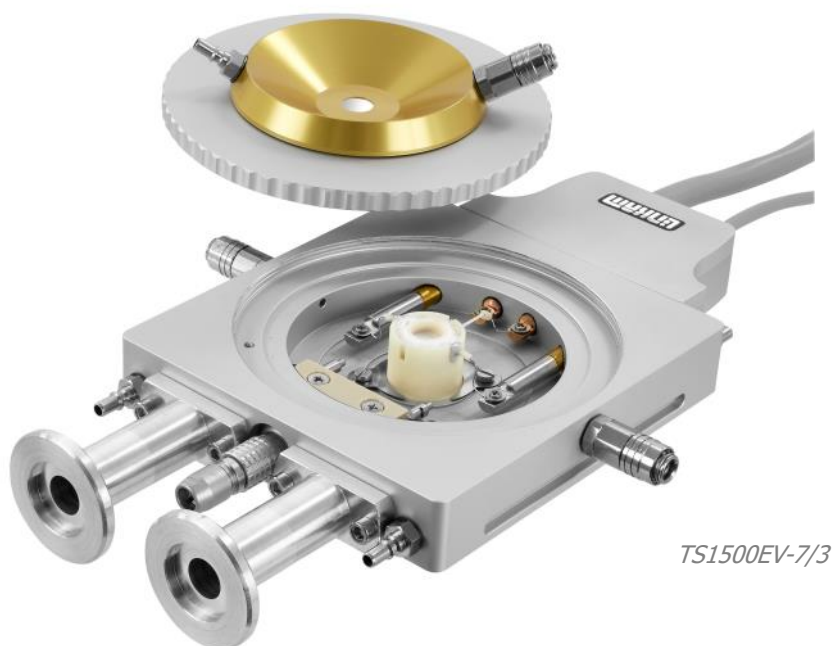

High Temperature

Accurate temperature control from ambient up to 1500°C at rates from 0.1°C to 200°C/min

Enclosed Sample Chamber

The ceramic sample cup and heat shield provide an enclosed micro-oven

Imaging Techniques

Compatible with Light Microscopy, Raman, X-ray and more

TS1500EV-7/3

The TS E series are versatile heating stages for samples, where high temperature and high speed heating are required alongside outstanding thermal stability. They feature a range of different heater sizes and have a thermocouple embedded close to the surface for accurate temperature measurements.

The sample is placed inside the ceramic sample cup where it is heated from underneath as well as from the sides, up to an impressive 1500°C at a maximum rate of 200°C/min. The stage body and large diameter quartz lid window are kept at a safe temperature by sealed circulating water. Precision quick-release gas connectors at the sides of the stage body can be used to purge the sample chamber with inert gas.

Our NEXUS software can be used to record the entire experiment and associated images, which can then be displayed as a chart or exported for further analysis.

A system requires both a TS E series stage and a T96-S controller, which is available with either NEXUS software for computer control, or a LinkPad touch screen for stand-alone control.

Features

HIGH TEMPERATURE

Optimised for the study of ceramics, composites, metals and geological samples with temperatures ranging from ambient up to 1500°C. The stage body is water-cooled for work above 300°C.

HEATING RATES

Wide range of heating rates from 0.1°C up to 200°C/min, ideal for state transition experiments.

TEMPERATURE STABILITY

< 1°C

VACUUM

Variants supporting vacuum are available.

CUSTOM OPTIONS

Please contact us with details of your requirements.

TS1000E-17/3

Temperature range : Ambient to 1000°C

Sample cup : 17mm \varnothing x 3mm depth

Sample manipulation : No

Electrical connections : 2 pin LEMO connector & posts

Vacuum compatible : No

RHGen compatible for humidity control : No

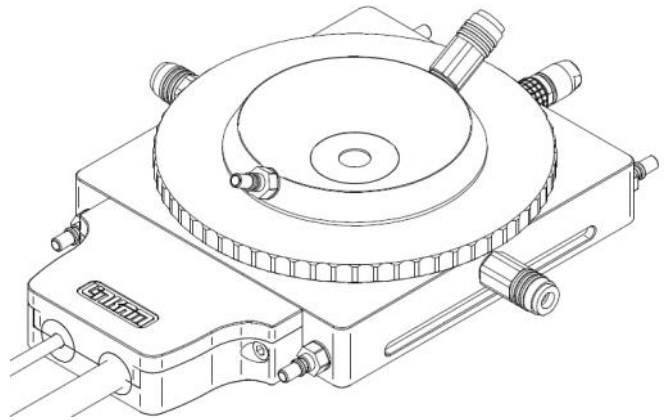

TS1000EV-17/3

Temperature range : Ambient to 1000°C

Sample cup : 17mm \varnothing x 3mm depth

Sample manipulation : No

Electrical connections : 2 pin LEMO connector & posts

Vacuum compatible : 1×10^{-3} mBar

RHGen compatible for humidity control : No

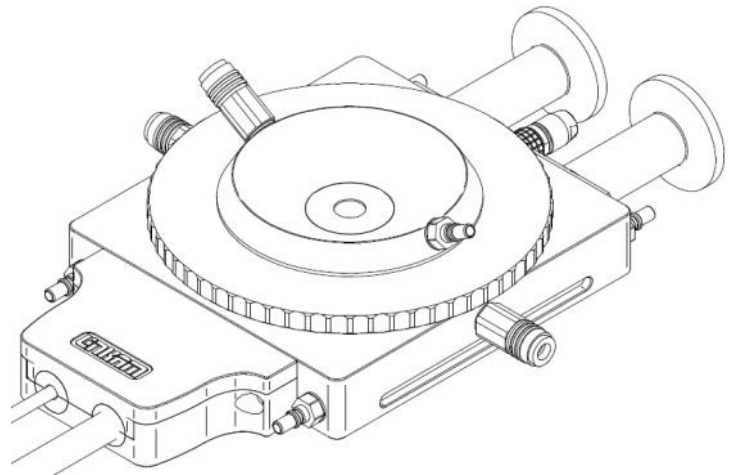

TS1000EV-PB4

Temperature range : Ambient to 1000°C

Sample cup : 17mm \varnothing x 3mm depth

Sample manipulation : No

Electrical connections : 4 X BNC & probes

Vacuum compatible : 1×10^{-3} mBar

RHGen compatible for humidity control : No

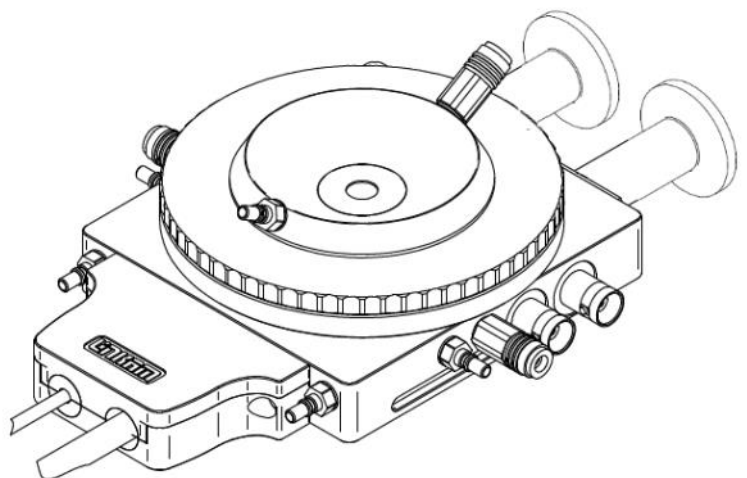

TS1200E Electrical Stages

TS1200E-10/5

Temperature range : Ambient to 1200°C
Sample cup : 10mm \varnothing x 5mm depth
Sample manipulation : No
Electrical connections : 2 pin LEMO connector & posts
Vacuum compatible : No
RHGen compatible for humidity control : No

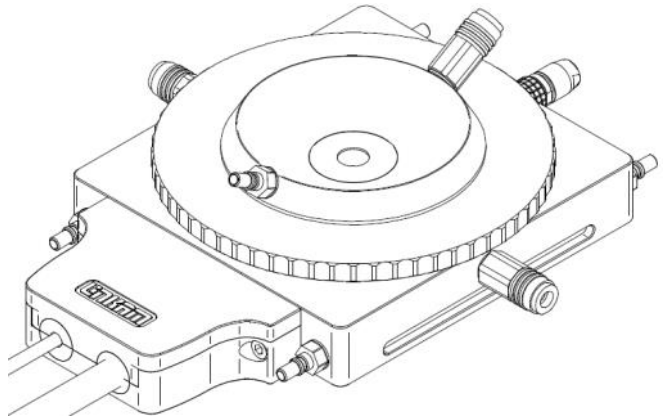

TS1200EV-10/5

Temperature range : Ambient to 1200°C
Sample cup : 10mm \varnothing x 5mm depth
Sample manipulation : No
Electrical connections : 2 pin LEMO connector & posts
Vacuum compatible : 1×10^{-3} mBar
RHGen compatible for humidity control : No

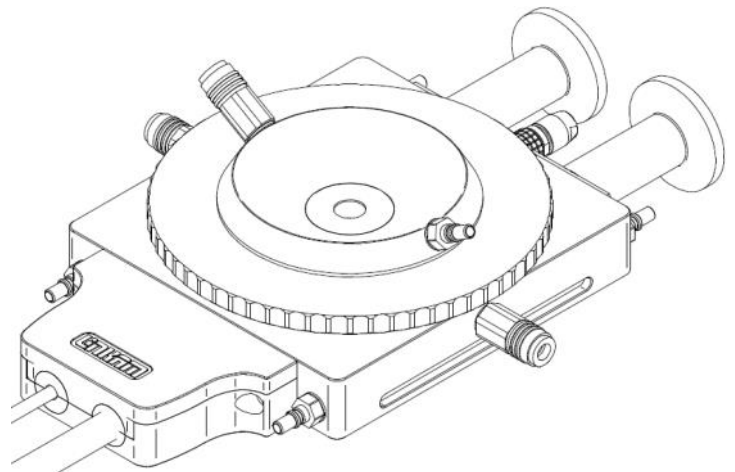

TS1200E-PB4

Temperature range : Ambient to 1200°C
Sample cup : 10mm \varnothing x 5mm depth
Sample manipulation : No
Electrical connections : 4 X BNC & probes
Vacuum compatible : No
RHGen compatible for humidity control : No

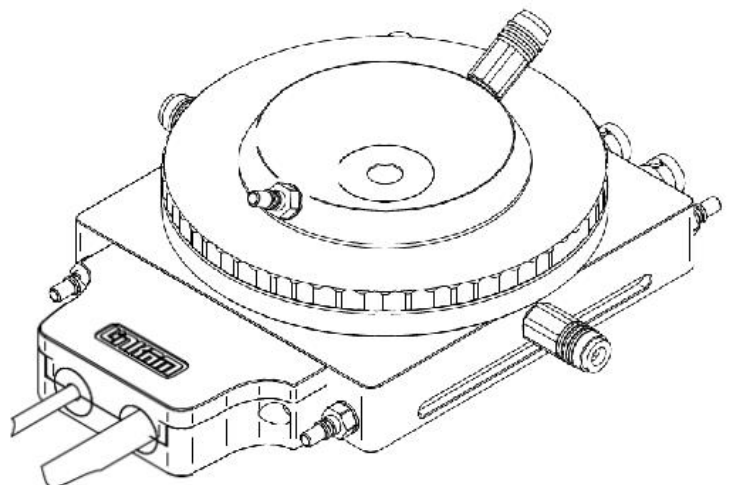

TS1500E-7/3

Temperature range : Ambient to 1500°C
Sample cup : 7mm ø x 3mm depth
Sample manipulation : No
Electrical connections : 2 pin LEMO connector & posts
Vacuum compatible : No
RHGen compatible for humidity control : No

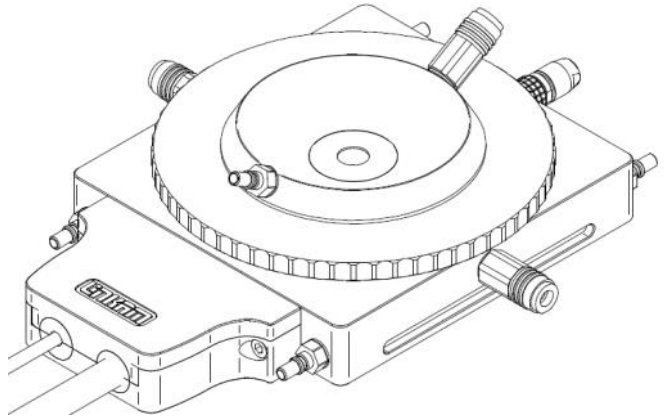

TS1500EV-7/3

Temperature range : Ambient to 1500°C
Sample cup : 7mm ø x 3mm depth
Sample manipulation : No
Electrical connections : 2 pin LEMO connector & posts
Vacuum compatible : 1×10^{-3} mBar
RHGen compatible for humidity control : No

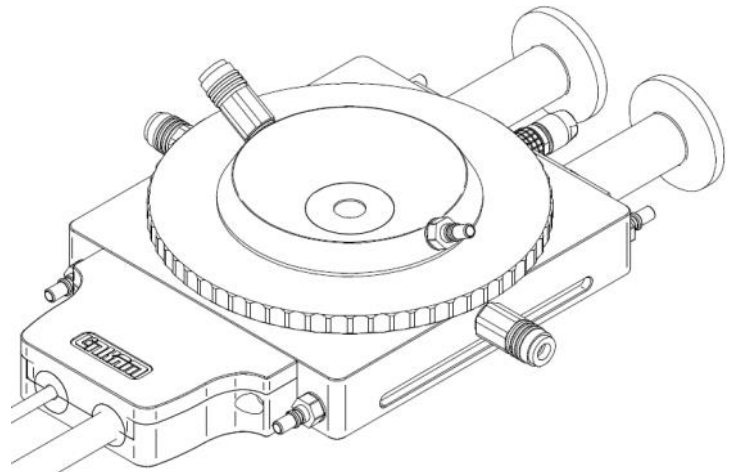

TS1500EV-PB4

Temperature range : Ambient to 1500°C
Sample cup : 7mm ø x 3mm depth
Sample manipulation : No
Electrical connections : 4 X BNC & probes
Vacuum compatible : 1×10^{-3} mBar
RHGen compatible for humidity control : No

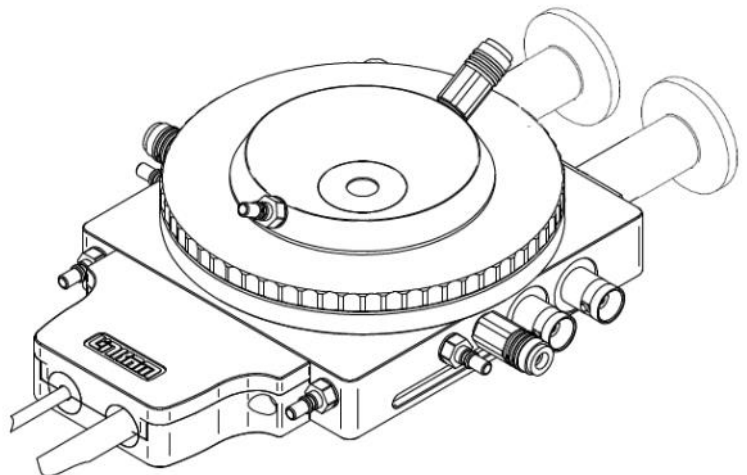

TS1500E Electrical Stages

TS1500E-7/6

Temperature range : Ambient to 1500°C

Sample cup : 7mm \varnothing x 6mm depth

Sample manipulation : No

Electrical connections : 2 pin LEMO connector & posts

Vacuum compatible : No

RHGen compatible for humidity control : No

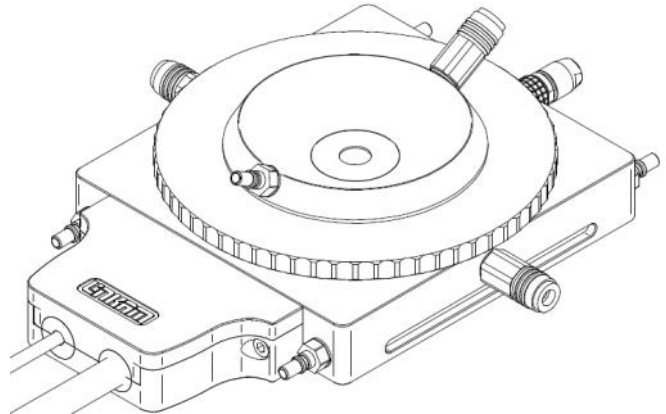

TS1500EV-7/6

Temperature range : Ambient to 1500°C

Sample cup : 7mm \varnothing x 6mm depth

Sample manipulation : No

Electrical connections : 2 pin LEMO connector & posts

Vacuum compatible : 1×10^{-3} mBar

RHGen compatible for humidity control : No

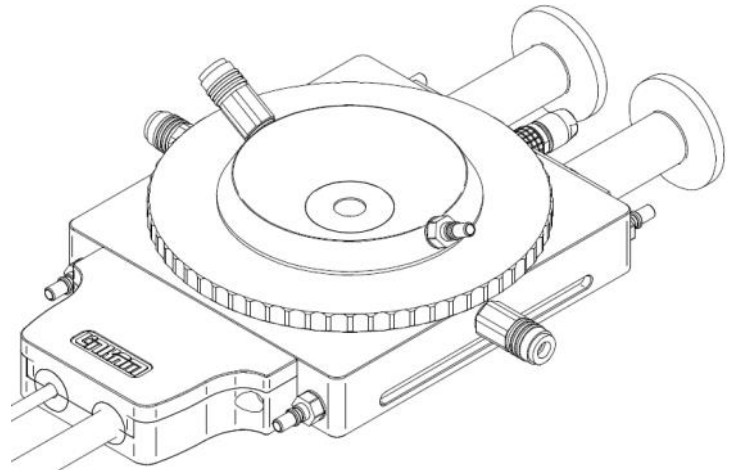

MFS



Page 24

The MFS (Modular Force Stage) is designed to characterise the mechanical properties of samples with temperature and environmental control modules. It can test tension, compression, and multi-point bending of various materials, such as polymers, metals, ceramics, biomaterials, and nanomaterials.





Tensile and Compression

A wide range of grips to accommodate different samples

Wide Range of Forces

Interchangeable options for tension and compression of 0N up to 600N

Multiple Control Options

Full control of speed, distance, movement mode, applied force and temperature

Linkam's MFS is designed to characterise the mechanical properties of your samples and is the successor to the TST tensile stage with increased sensitivity, resolution and support for compression. The modular design allows users to have an additional level of control over experimental conditions, alongside the ability to change grips, force beams, and heater types; for example a liquid cell, or a temperature module that can be controlled from $< -195^{\circ}\text{C}$ up to 600°C . These additional options accommodate a wide range of samples, from single fibre threads to reinforced composites, and environmental control using the humidity or heated liquid cell modules.

The MFS allows the user to characterise and image all types of samples. The understanding of thermo-mechanical properties is increasingly important in the development of next-generation materials. Existing materials are being deployed in new environments, and innovative new materials and composites are being developed to meet the demand for stronger, more durable samples that can handle a range of environmental conditions, from inside the human body to outer space.

The MFS can be used with reflected or transmitted illumination as well as with other popular characterisation techniques such as X-ray, Raman and FT-IR. Its sample chamber can also be gas purged via the built-in gas ports. Additional options for humidity control and electrical contact posts are available.

A system requires the MFS stage, a T96-S temperature controller and LINK software for computer control. For cooling below ambient temperatures, an optional LNP96 liquid nitrogen pump is also available.

Features

COMPRESSION AND TENSILE FORCE

Test the compressive and tensile properties of your sample relative to temperature, and capture high resolution images of the structural changes in situ.

WIDE RANGE OF CONTROL PARAMETERS

Speed of jaws, distance moved and the force applied can be varied relative to temperature and environment.

ENCODED DISTANCE MEASUREMENT

Built-in high resolution encoder for measurement of changes in length. Dual threaded leadscrews ensure the middle of the specimen stays centrally located.

MODULAR DESIGN

Grips, force beams, heaters and lids can be easily changed to accommodate a wide range of sample types.

HUMIDITY

Add the RHGen humidity controller to your system to accurately control the relative humidity around your samples.

CUSTOM OPTIONS

Please contact us with details of your requirements.

Design the system you need

Linkam's MFS has a wide variety of modular components which allow you to customise your system to handle a broad range of mechanical characterisation experiments. Modules include heated and unheated base plates, electrical connections, humidity options and heated liquid cells. A range of force beams are available including a highly sensitive 2N beam for single fibre applications and a 600N beam for failure testing of structural composites. In addition, a wide range of custom module designs and grip options are available. We are constantly working with leading scientists to add more module options.

Base Modules

- MFS Ambient (room temperature)
- MFS60 (ambient to 60°C)
- MFS350 (<-195* to 350°C)[†]
- MFS600 (<-195* to 600°C)

Large Area Heaters:

- MFS350-LA (ambient to 350°C)
- MFS420-LA (ambient to 420°C)

*With the addition of an optional LNP96

[†] Vacuum compatible option available

Lid Modules

- Standard, 50mm or 16mm aperture
- Humidity, RHGen compatible, including sensor
- Large, 97mm aperture

End Port Modules

- Blank
- Electrical Connections

Force Beam Modules

2N, 20N, 200N & 600N

Liquid Cell Module

(Compatible with MFS Ambient and MFS60 Base Plate options)

Tensile and Compression Grip Modules

Included as standard:

- Standard Grips (44/33mm[†])
- Serrated Grips (23/13mm[†])
- 3-Point Bending Grips

Additional options include:

- Pin Grips
- 44 mm Serrated Grips (44/33mm[†])
- Grip Extenders for short samples (44/33mm[†])
- Zero Gap Grips (compatible with ISO 11566 and ASTM D3822 methods)

[†] Grip width / width excluding screws

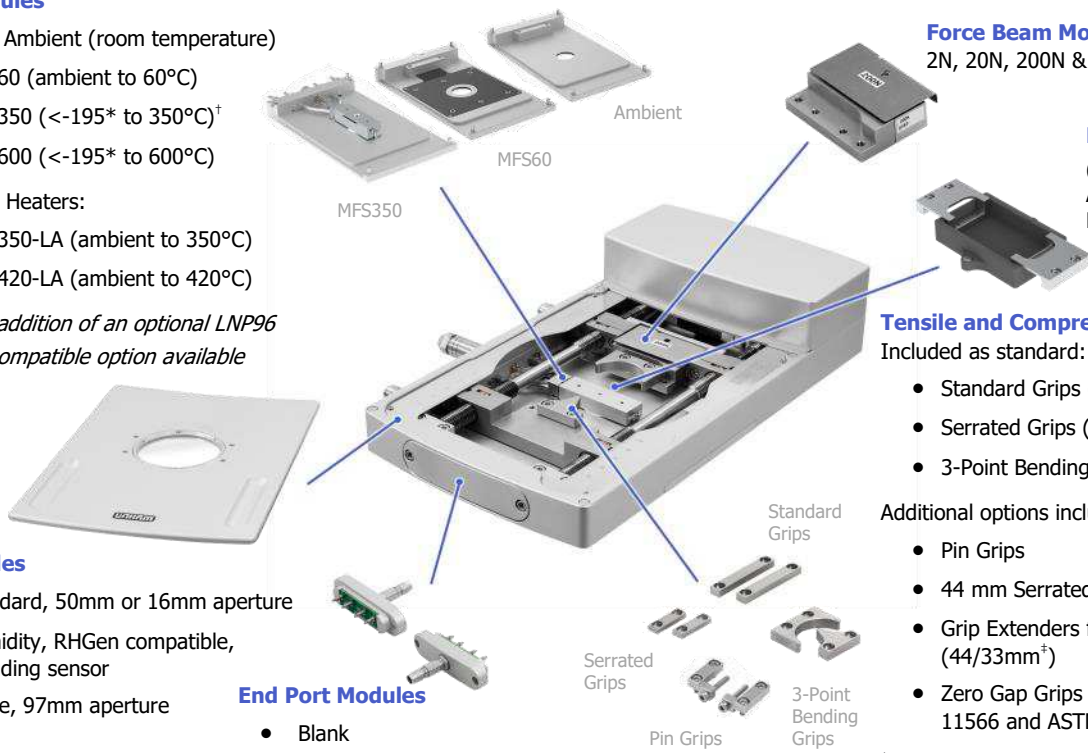

Graphical Data

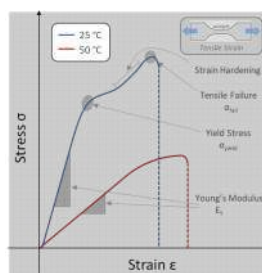
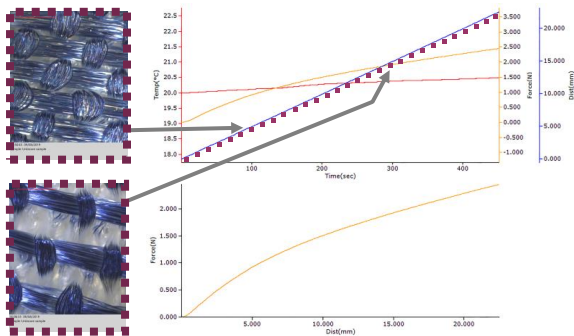

Analyse the mechanical properties of your samples with LINK software. Combine it with the LINK imaging module for in situ visualisation of your samples throughout your experiment.

Real-time graphs are displayed as the experiment is run. You can visualise your data in both temperature-time and force-distance graphs and export it for more detailed analysis.

Technical Specification

Distance Resolution

1µm

Tensile and Compressive Force Range

0N to 2, 20, 200 or 600N

Force Resolution (Maximum Force)

1x10⁻⁵N (2N) 1x10⁻⁴N (20N)
1x10⁻³N (200N) 1x10⁻²N (600N)

Temperature Range

< -195°C up to 600°C *

Temperature Stability

<0.1°C

Maximum Travel

85mm

Speed Range

0.1 to 5000 µm/s *

Movement Modes

Step Velocity
Tensile/Compressive Cycling
Controlled Force

* Dependent on chosen modules

Linkam Custom Projects and Solutions

Do you and your research team need a custom designed solution?

Linkam stages are designed and manufactured in-house. We have an experienced R&D team made up of mechanical, electronics and software design engineers. Our R&D department has dedicated advanced CAD machining centres, 3D printing, and 3D design software to enable us to create and manufacture sophisticated instruments, electronics and software specific to your individual needs.

We are happy for scientists to approach us with their ideas for stage modification, or to conceptualise a new custom-built project. Many of our products are modified as a result of feedback from users around the world.

We design and manufacture custom stages for a wide range of applications for leading research universities and multinational pharmaceutical and materials companies.

Due to the continued high demand for Linkam custom projects we have established a cutting edge research and development facility in The Netherlands.

Please contact us to discuss your ideas for a new design or modified instrument.



Connectors

Some applications require a larger number of electrical connections. We have produced numerous adapted stages with extra connectors, such as this example with 2 x 4 pin LEMO connectors & posts.

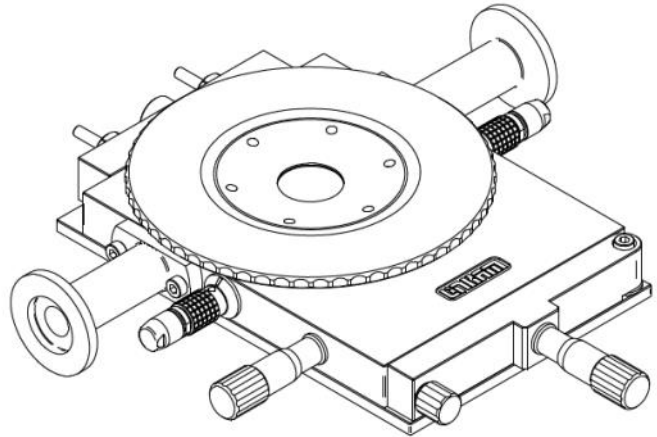

Our standard electrical stages are fitted with either LEMO or BNC connectors, we strive to be flexible and have produced a number of stages for customers that needed different types of connectors, or even a mix of types, like this example with both LEMO and Triax connectors.

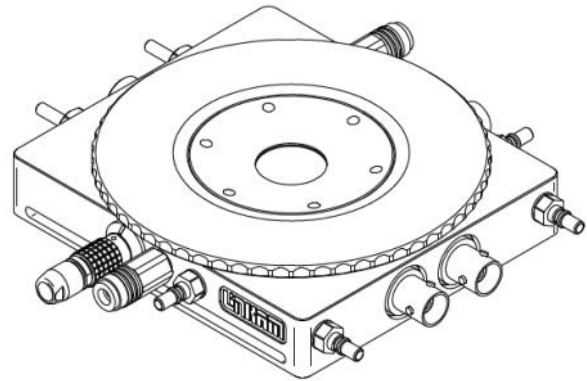

Some customers have had applications that are very sensitive to grounding scheme and have required connectors with a collar to electrically isolate from the stage body.

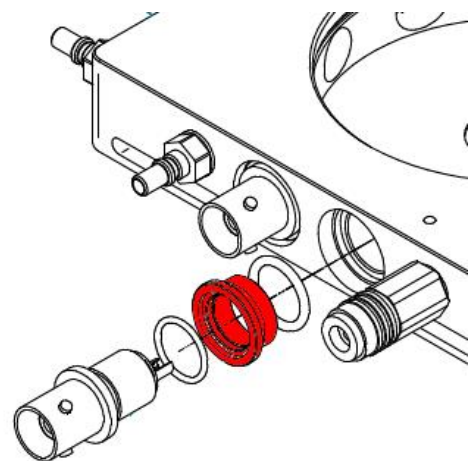

Example Customisations

Environment

Our standard range of electrical stages features models that are suitable for vacuum or humidity, or as in this example an LTS style stage with lock down lid. Existing or bespoke features can be built into custom stages.

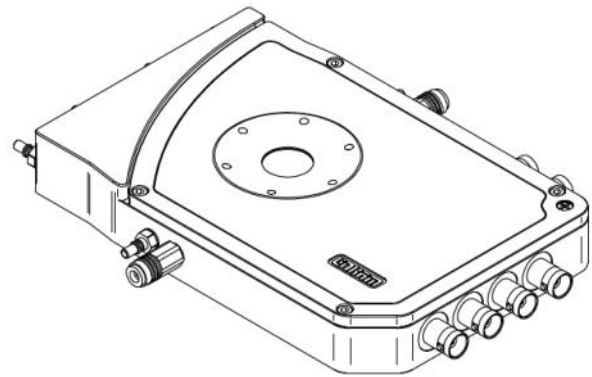

We have made stages for customers needing larger windows, useful for sample observation or sample illumination in solar research.

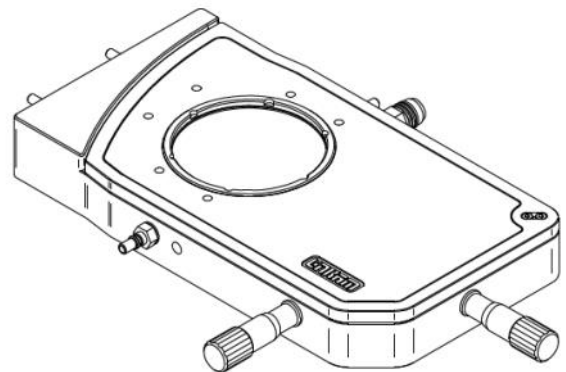
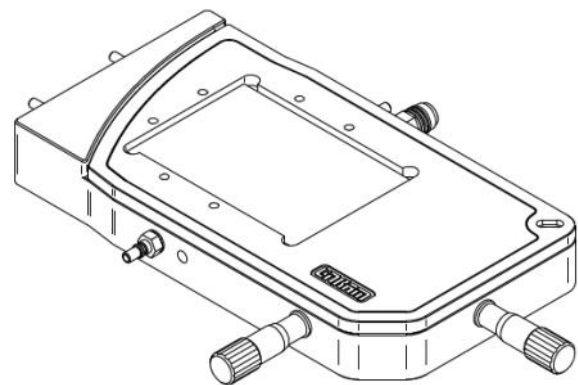

We can supply lid spacers, useful for higher voltage work when there is a risk of arcing to the stage body, or simply to improve probe access.

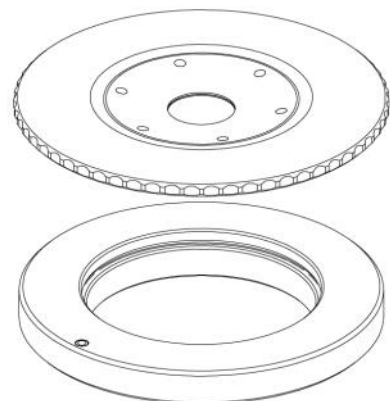

NEXUS

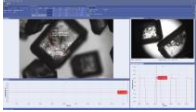

Page 30

NEXUS, our market-leading software, is designed to provide an intuitive and seamless user experience. It supports all standard Linkam stages (THMS / HFS / LTS / TS / PE / HS / BCS / FTIR / CCR / MDS and CMS families), offering precise control over heating and cooling rates, limit and hold time with unlimited ramps.

LINK

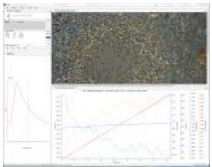

Page 32

Linkam's LINK software for Windows supports all our stages, and remains the current option for MFS / CSS / DSC stages.





Image Your Sample

Take synchronised images and videos as your sample evolves with temperature

Experimental Control

Use NEXUS for sample analysis to control temperature, vacuum, pressure, humidity and imaging

Image Analysis

Calibrated measurement of feature size and area, or view structural phase transitions

Take control of your experiment with NEXUS software. Alongside NEXUS's market-leading temperature control features, there are optional modules for the recording and analysis of images during your experiment. Adding imaging to your system greatly enhances its capabilities, allowing you to directly monitor and analyse changes to the physical characteristics of your sample.

The range of optional modules available for NEXUS includes Image Capture, Extended Measurements, Reporting, TASC (Thermal Analysis by Surface Characterisation), 21 CFR 11, and a full Software Development Kit (SDK).

NEXUS supports Linkam's T96 and T95 controllers, is a native 64 bit application compatible with Windows 10/11 64 bit, and currently supports the THMS / HFS / LTS / TS / PE / HS / CCR / MDS and CMS families of our stages.

Features

- Live display of current status for easy monitoring
- Full control of heating and cooling rates, limit and hold time of unlimited ramps
- The ability to cycle a set of ramps a specified number of times
- Row-by-row control of vacuum and humidity, synchronised with temperature
- Full five-point temperature calibration
- Trigger I/O for synchronisation with other equipment
- The ability to hold a ramp until non-temperature conditions are met, such as vacuum or RH level
- Real-time chart of temperature and other measured parameters
- Automatic setup of controls and parameter limits based on stage type connected
- Data export to CSV and Excel .XLS
- Tools to compare data-runs
- The ability to rewind and review data whilst still recording
- Docking environment to customise the screen layout
- Multiple themes for a better user experience

Image Capture Module

Recording the temperature is only half the story. See how your sample evolves with changing environment such as temperature, humidity or vacuum.

Many materials change colour, shape and size with changing conditions. For example, thermotropic liquid crystals undergo phase transitions as the temperature is changed, and many materials change colour as they oxidise at higher temperatures. By acquiring images in addition to recording the sensor parameters, visual changes such as colour can be analysed and the size and shape of particles can be measured. All these changes can be easily correlated to temperature.

A range of NEXUS Image Capture Modules and cameras are offered, making it easy to automatically capture images at specified points during an experiment. Input triggers are stored and marked on the chart for easy synchronisation with other equipment. Each image is stamped with the current temperature, (and other measured parameters), making offline analysis straightforward.

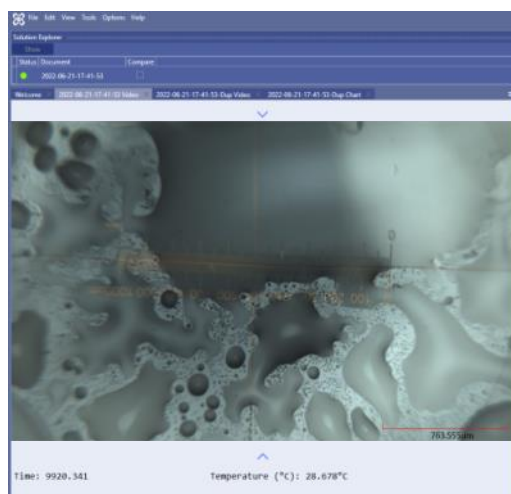

- Automated image capture with ramp
- Image export - multiple image types supported
- Distance calibration (Reticule supplied)
- Images linked to temperature chart for easy review
- Burn a scale bar into the image
- Rewind and review whilst still recording
- Image capture synchronised with temperature
- Zoom and pan the video
- Images stamped with temperature, time and other measured parameters
- Movie generator

Reporting Module

NEXUS Reporting automates the export of charts and images into a user customisable Microsoft Word document, saving the user time, and maintaining standardisation of report format.

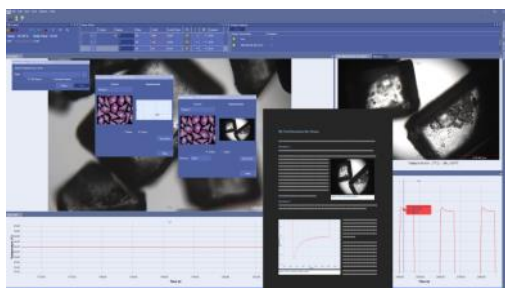

Extended Measurements Module

NEXUS Extended Measurements adds a new level of analysis and annotation. Precisely measure the properties of all regions of interest on your sample image.

- Multiple image measurement tools for distance, angle and area
- Fully calibrated measurements
- Annotation tools
- Measurements and annotations can be burned into the image for quick and easy analysis, and for pasting directly into a report
- Copy and paste measurements

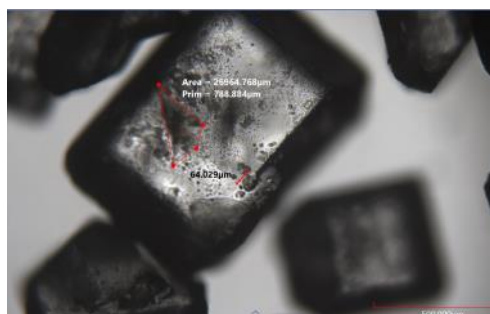

Temperature Control, Graphing, Imaging and Measurement Tools

Take control of your experiment with LINK software. Alongside LINK's temperature control features, there are optional modules for the recording and analysis of images during your experiment. Adding imaging to your system greatly enhances its capabilities, allowing you to directly monitor and analyse changes to the physical characteristics of your material such as colour, size, shape and phase transitions.

A range of optional modules, packaged with different cameras, are available for LINK. These include Image Capture, Extended Measurements, TASC (Thermal Analysis by Surface Characterisation), 21 CFR 11, and a full Software Development Kit (SDK).

LINK supports Linkam's T96 and T95 controllers and is a native 64 bit application compatible with Windows 10 64 bit. Modules are compatible with all versions of LINK. LINK's standard features include:

- Live display of current status for easy monitoring.
- Full control of heating and cooling rates, limit and hold time of up to 100 ramps.
- Row-by-row control of vacuum, humidity, tensile force and shear modes controllable and synchronised with temperature.
- Full five point temperature calibration.
- Trigger I/O for synchronisation with other equipment.
- Real-time chart of temperature and other measured parameters.
- XY coordinate mapping — micro stepped motors enable micron repeatable position resolution and recall for selected stages including the CMS196 and MDS600.
- Automatic setup of controls and parameter limits based on stage type connected.
- Includes .NET Component for easy integration into 3rd party applications.

Image Capture Module

Many materials change colour, shape and size with changing conditions. For example, thermotropic liquid crystals undergo phase transitions as the temperature is changed, rubber can tear when under tensile force and many materials change colour as they oxidise at higher temperatures. By acquiring images in addition to recording the sensor parameters, visual changes such as colour can be analysed, the size and speed of a tear can be characterised and the size and shape of particles can be measured. All these changes can be easily correlated to temperature.

A range of LINK Image Capture Modules and cameras are offered, making it extremely easy to automatically capture images at specified points during an experiment. Input triggers are stored and marked on the chart for easy synchronisation with other equipment. Each image is stamped with the current temperature (and other measured parameters) so offline analysis is straightforward.

- Image resolution up to 2447x2048 (depending on camera selected).
- Burn a scale bar into the image. Includes a reticule for easy calibration of your optical system in X and Y.
- Capture still images and video, synchronised with your temperature and environmental profiles.
- Trace how your sample changes with temperature - click on the purple points on the profile graph to see images at the exact temperature of interest.

Extended Measurements Module

LINK Extended Measurements adds analysis and annotation. Precisely measure the sample properties of all regions of interest on your sample image.

- Multiple image measurement tools for distance, angle and area.
- Fully calibrated measurements.
- Annotation tools.
- Measurements and annotations can be burned into the image for quick and easy analysis, and for pasting directly into a report.

TASC Module

The TASC Image Analysis module is a thermal analysis system. Linkam and Cyversa have developed, in partnership, this revolutionary thermal technique that provides characterisation scientists with a powerful new tool for analysing materials.

Turn your temperature control microscope stage into a thermal analysis laboratory capable of measuring glass and melting transitions in many different materials including opaque samples. A new image analysis algorithm enables structural changes in any sample to be tracked and quantified.

- More sensitive than DSC at low heating rates and for small samples.
- Local thermal analysis at the exact position the change occurs - measure local phase changes on a microscopic level.
- Kinetic parameters over a wider range of heating rates than any conventional method.
- Compatible with many Linkam stages such as the THMS, LTS, and TS ranges, as well as our DSC stages where TASC provides complimentary information.

Controllers, Accessories & Microscopes

RHGen



Page 34

The RHGen is a Relative Humidity Controller designed to provide environmental sample control to compatible stages. It provides precise control in a compact, self-contained package without requiring an external dry air supply from 5% to 95% RH.

Imaging Station



Page 36

The Imaging Station is a digital imaging system designed to be used with Linkam's temperature-controlled stages with high-resolution, research grade sample imaging. The unique and innovative swing feature simplifies the sample change procedure for maximum sample throughput.

WCP



Page 39

The WCP (Water Circulation Pump) is designed to provide optimised water cooling to Linkam's range of temperature and environmental control stages. It has been designed specifically for Linkam stages where water cooling is required (Peltier stages and all other stages at temperatures above 300°C).

T96



Page 40

The T96 Controller is a universal controller required for all Linkam stages except the CMS196. It can be controlled through NEXUS software (30) using the USB interface, or the LinkPad.

LNP96



Page 40

The LNP96 is a unique cooling system that significantly enhances the capabilities of compatible stages. It employs precise control of liquid nitrogen flow, enabling stages to cool at linear rates as fast as 100°C/min or as slow as 0.01°C/min. The LNP96 can be added as an option to many Linkam systems to allow cooling down to < -195°C.

Vacuum Accessories



Page 41

Linkam provides various accessories to improve the performance of vacuum stages, such as a rotary pump for pulling a vacuum, a pressure gauge for measuring the vacuum level, and an MV196 motorised valve for controlling the vacuum pressure.

RHGen

Humidity Controller for your Sample Environment



*Imaging Station,
digital camera and
THMS600-RH*

RHGen

Inert Gas Regulator

Sensor at Sample

Accurate humidity measurements and control around the sample

Smart Desiccant System

Automated self-contained drying mechanism allows long-term testing without dry air

Cross-system Compatibility

Humidity control compatible with Linkam devices and third-party chambers

The RHGen Relative Humidity Controller is designed to provide environmental sample control to the range of Linkam stages. It allows precise control of water vapour in the environment around a sample without the need for an external dry air supply.

The smallest change in RH% can have huge implications on the characteristics of a sample and how it behaves. When combined with a Linkam stage, or other sealed chambers, the RHGen can be used to control the RH% between 5%-90% at temperatures from ambient to 85°C (dependent on device).

Unlike many other humidity systems, the feedback sensor is located close to the sample block, ensuring accurate humidity control. The RHGen can be combined with light microscopy, Raman, FT-IR and X-ray to further characterise samples.

The RHGen controller is compatible with a wide range of Linkam stages, as well as third-party devices with sealed chambers. It is supplied with a small sealed chamber as standard, which can be used with humidity validation samples.

The system contains a specially designed, automated recycling desiccant system which, combined with the ability to top up the water even during a run, allows the system to provide humidity control for months at a time.

Features

INTEGRATED DESICCANT SYSTEM

Ambient air is dried through a specially designed automatic desiccant recycling system which provides humidity control for months at a time without the need for a costly dry air supply.

SMART COMPACT DESIGN

The small size of the controller conserves vital benchtop space and provides a neat compact humidity system. Magnetic mounting of the bottle and front panel enable easy water changing, even during an experiment.

SENSOR INSIDE THE SAMPLE CHAMBER

A sensor is mounted inside the chamber to create a feedback loop to the controller ensuring precise reporting and control of RH between 5%-90% at temperatures from ambient to 85°C (dependent on stage).

MULTI-SYSTEM COMPATIBILITY

Humidity-compatible versions of Linkam's THMS600, LTS420 and MFS stages are available, along with support for other sealed chambers.

INERT GAS SUPPORT

The optional Inert Gas Regulator (IGR) allows inert gases such as Nitrogen and Argon to be used as a carrier gas with the RHGen.

VALIDATION

A variety of certified salt solutions are available from Linkam to accurately validate the humidity sensors.

CUSTOM OPTIONS

Please contact us with details of your requirements.

The precision humidity control of the RHGen is used in combination with Linkam stages and other sealed chambers for a range of applications in research and industry worldwide. These include:

Semiconductor and Electrical

Environmental stability is very important in the lifetime testing of all electronic devices. Leading multinational companies and research institutes use the RHGen to study water ingress on internal electrical components, polymeric films, aerospace and marine coatings.

Photovoltaics

Conductivity

Corrosion



Food Research

The RHGen system is used by leading food and drink manufacturers to study the effect of humidity, or dry air, on food storage conditions, and how humidity affects food samples while heating.

Long-term Storage

Oral Processing

Microorganism Growth



Pharmaceuticals

The RHGen has many applications within the pharmaceutical field, from drug discovery to manufacturing and quality assurance. Humidity control facilitates the understanding of the behaviour and breakdown of pharmaceutical compounds, and how their packaging protects them.

Shelf Life

Dissolution

Packaging



Technical Specification

Humidity Range

5% - 90% RH (dependent on stage and with a stage temperature between ambient and 85°C)

Sensor Accuracy

Up to +/- 1.5%

Stability

+/- 0.5% (at control value)

Size

136 x 246 x 265mm

Compatible Linkam Stages

THMS600-RH, LTS420-RH, MFS-RH and others

Sealed Chamber Capacity

Maximum 2000ml

Imaging Station

Digital Imaging with Easy Sample Access



3L Dewar

LinkPad, LNP96 and T96
Temperature Controller

Imaging Station, digital
camera and THMS600

Image Your Sample

Take synchronised images and videos as your sample evolves with temperature

High-Resolution Camera

Use NEXUS software for sample analysis and imaging, controlling temperature,

Pivoting Arm

Allows easy access and quick sample changing while maintaining image focus

Imaging Station

The Imaging Station provides an easy-to-use, ergonomic and high-performance imaging system with superior sample throughput compared to a standard microscope. It is compatible with the majority of Linkam's temperature and environmental control systems. The high-resolution camera can be used to capture images, time-lapse recordings and videos of your samples whilst also controlling the temperature and environmental conditions.

The unique pivoting mechanism allows easier access to your Linkam stage, simplifying sample changes and improving the workflow in your laboratory. It has a built-in LED light source for transmitted light with additional options available for reflected light, polarisation and phase contrast imaging.

The Imaging Station is also compatible with a range of long working distance objective lenses which can be easily switched with the quick-release mechanism.

Features

DEDICATED TEMPERATURE CONTROL IMAGING SYSTEM

Designed to provide an easy-to-use, yet high-performance, digital imaging platform for Linkam stages. Use with Linkam stages and our powerful T96-S controller to heat and cool samples from 1500°C down to <-195°C.

PIVOTING ARM

The pivoting arm gives greater access to the sample while the sturdy frame provides the perfect platform for imaging using Linkam stages, and also allows quick and easy access to change samples between experiments.

STANDARD MICROSCOPE OBJECTIVES UP TO 50X MAGNIFICATION

Suitable for use with many standard microscope objectives. Use with our high-performance camera to take synchronised images and videos as your sample evolves with temperature.

HIGH QUALITY DIGITAL IMAGING

Record images of your sample automatically during your experiment. Exceptional image quality is standard as a result of our unique configuration which is designed specifically for temperature-controlled microscopy applications.

TRANSMITTED AND REFLECTED LIGHT

Transmitted light is provided by a specially designed LED illuminator to give uniform and constant illumination. For reflected light applications the optional RLS20 features 20 LED lights and is connected through a USB port. Light intensity is controlled through NEXUS software. Other features include a polariser, analyser and option for phase contrast imaging and oblique imaging.

The Imaging Station has been specifically designed for use with Linkam's temperature-controlled stages. It combines high-performance optics with easy-access convenient sample handling and a fixed stage mount layout. These features offer advantages for temperature control applications and are not available on a typical standard microscope.

The Imaging Station is suitable for use with a wide range of objectives up to 50x magnification, as well as adaptors for polarised light. For optimal performance from your Linkam stage and Imaging Station, use Linkam's recommended high-resolution camera, in combination with advanced imaging and measurement modules for NEXUS software.

RLS20 - Reflected Light Source

For reflected light applications, the optional RLS20 features 20 LED lights and is connected through a USB port. Light intensity is controlled using NEXUS software.

Light is provided by a specially designed LED illuminator to give uniform constant oblique illumination.



Software Modules for Imaging and Measurements

Recording the temperature is only half the story. See how your sample shape and size evolves with changing environments such as temperature, humidity, vacuum or other parameters such as XY location. NEXUS can provide additional information about your sample characteristics.

A range of NEXUS modules are offered, making it easy to automatically capture and analyse images at specified points during an experiment. Optional modules to further enhance your system include **NEXUS Imaging** for synchronised image capture, **NEXUS Extended Measurements** for recording the measurement of key features in your images, **NEXUS 21CFR11** for data regulatory compliance and **NEXUS TASC** providing image analysis based thermal analysis.

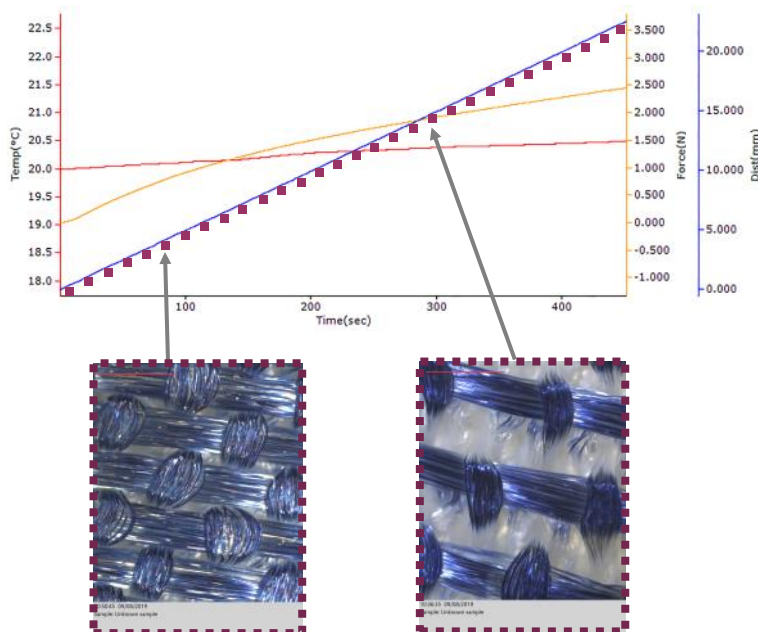

Imaging Station Camera & Technical Specification

High-Resolution Camera

Linkam provide a range of powerful yet compact camera solutions which meet the demands of the majority of research applications and are tailored to work with temperature-controlled microscopy setups. Choose from a range of high-quality cameras, compatible with Linkam's Imaging Station and many other microscopes, to capture images and videos of your sample while controlling thermal and environmental conditions.

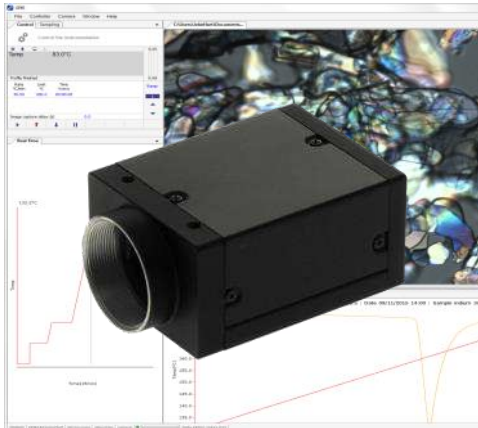

Image Capture Module	Sensor Type	Resolution	Pixel Size	XY Pixels
High-Performance Mono	CMOS	2.3 Mp	5.86 μm	1920x1440
High-Performance Colour	CMOS	3.2 Mp	3.45 μm	2048x1536
High-Resolution Colour	CMOS	5.1 Mp	3.45 μm	2464x2056

Technical Specification

Transmitted Light Source	LED transmitted illumination with variable intensity control.
Reflected Light Source	Optional LED reflected light adapter (RLS20) with full intensity control.
Size	265 x 200 x 340mm (LxWxH without C-mount or camera)
Compatible Linkam Stages	Most Linkam stages, including THMS600, HFS600, LTS420, PE120, TS1500, CSS450, MFS, DSC450, and others.
Objectives	Supplied with 10X brightfield objective lens with 10.6mm working distance 0.25NA. Compatible with standard microscope objectives. Optional objective adapters available for M25, M32, RMS threads. Includes spare objective loading adaptor.
Condenser/Polariser	Optimised strain-free condenser with 0.5NA and built in diaphragm – ideal for polarised light and phase imaging.
C-Mount	C-mount optimised for Linkam approved cameras.



Compact and Efficient

Small footprint device delivers powerful water circulation

Remote Operation

Control remotely and automatically with LinkPad or NEXUS software

Multi-system Compatibility

Water circulation compatible across Linkam's range of stages, including our Peltier family

The WCP is designed to provide optimised water cooling to Linkam's range of temperature and environmental control stages.

When used with a Linkam Peltier stage the system will be able to hold sample temperatures as low as -30°C *.

The WCP has a compact footprint allowing it to be placed neatly alongside Linkam controllers. Where bench space is a premium, the unit can be positioned underneath the work surface or up to 3 metres away from the stage.

Features

PRESSURE OPTIMISED FAN

A pressure optimised fan coupled with a full copper radiator makes for efficient heat dissipation and quiet operation.

POWERFUL BRUSHLESS PUMP

A powerful pump circulates the water around the system. The increased pumping performance allows longer tubing to be used.

BUILT-IN TOUCH-PANEL DISPLAY

The touch-panel display provides control as well as visual feedback of the current status of the WCP.

MULTI-SYSTEM COMPATIBILITY

Compatible with the majority of Linkam products from the Peltier stage range providing improved cooling performance, to the High Temperature TS range, providing efficient stage body cooling.

BUILT-IN SAFETY CONTROLS

The unit constantly monitors the fan speed, pump current and water temperature and will stop the run if any of these parameters stray outside of the safe values to prevent damage to the equipment.

COMPACT SIZE

The compact size of the WCP enables it to be placed neatly alongside the Linkam controllers, taking up very little bench space.

SMALL WATER VOLUME

The highly efficient cooling system requires only 300ml of water.

Technical Specification

Temperature Range

The WCP helps control Peltier stages down to -30°C *, or cool high temperature stages running above

Size

360 x 180 x 80mm

Compatible Linkam Stages

Peltier stages, High Temperature stages, THMS600, LTS420, MFS, DSC450 and others.

Water Capacity

300ml

Tube Length

Standard Tubing 1m
3m Tube Kit available

* with an ambient temperature of 21°C

Controllers and Accessories

T96 Temperature Controller

The T96 can be controlled through software using the USB interface or the high resolution LinkPad, an ergonomic touch screen display, which enables the user to quickly enter experimental parameters for the hot stage.

A wide range of controls has been implemented for each line (ramp) of the temperature profile, including parameters such as vacuum, pressure, tensile speed and force.



T96 Temperature Controller and LinkPad

T96-P model supports the following Linkam stage families:

- PE100
- PE120
- LTS120

T96-S model supports the following Linkam stage families:

- THMS
- HFS
- LTS420
- TS
- BCS
- FTIR
- MFS
- DSC
- CSS
- HS
- CCR

High Speed Temperature Ramps

Temperature ramps of up to 200°C/min (dependent on stage attached).

High Temperature Resolution

Temperature measurement using a PT100 platinum sensor with better than 0.01°C resolution.

USB Interface

The standard USB interface allows the controller to be connected to a PC.

Optional SDK

The optional SDK provides a platform for the easy integration into third-party software applications. Windows and Linux versions are available.

LinkPad

The LinkPad high resolution touch screen controller provides complete stand-alone control. Up to 100 ramps can be programmed with separate control of parameters including temperature, vacuum and humidity.



LinkPad

LNP96 Liquid Nitrogen Pump

The LNP96 cooling system allows precise control of liquid nitrogen flow to enabling specific stages to be controlled at linear cooling rates as fast as 100°C/min or as slow as 0.01°C/min. The unique design of the LNP96 reduces noise and vibration and is automatically controlled by the T96 controller. A cooling system consists of the control unit housing the pumps and a Dewar. The LNP96 can be added as an option to several Linkam systems to allow cooling down to < -195°C.



3L Dewar and LNP96

Vacuum Pump



Vacuum Pump and MV196 Motorised Valve

The Linkam vacuum pump with mist filter is a versatile accessory that enables vacuum conditions for any of our vacuum systems. It can reach vacuums as low as 10^{-3} mBar, allowing for precise control and observation of samples under reduced pressure.

The vacuum pump with oil filter is an ideal addition to sub-ambient temperature applications where moisture control is essential, such as electrical measurements. By creating a dry and stable environment, the vacuum pump can prevent condensation and corrosion that may affect the sample quality and performance.

Vacuum Gauge

The Linkam Vacuum Gauge is a durable and convenient accessory that measures the vacuum level inside your stage. It attaches directly to the stage flange for precise monitoring of sample pressure.



Vacuum Gauge

Remote Mains Switch

The Remote Mains Switch (RMS) allows users to control power to an external device directly from within Linkam control software (NEXUS/LINK) or a LinkPad using the I/O trigger functionality. The RMS allows the user to switch a mains-powered device such as a vacuum pump on and off remotely by turning it on mid-experiment and off at the end.



Remote Mains Switch

MV196 Motorised Valve

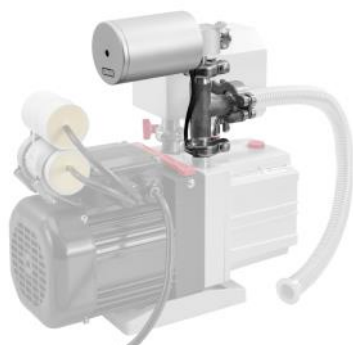

Vacuum Pump (faded) and MV196 Motorised Valve

The MV196 is a motorised valve system enabling precise control of the vacuum level between 0.1 to 100mBar.

It can be used in conjunction with all of Linkam's vacuum-compatible instruments alongside the T96-S controller and a vacuum pump.

The vacuum set point can be controlled from either the LinkPad or NEXUS software. The MV196 is shown here with an optional vacuum pump.

 **McCRONE**
MICROSCOPES & ACCESSORIES
mccrone.com | 630-887-7100
Email: mmaorder@mccrone.com

Contact Details

Linkam Scientific Instruments Ltd.
Unit 9 Perrywood Business Park
Honeycrook Lane
Salfords
RH1 5DZ
United Kingdom

We make scientific instruments that help characterise materials from polymers to biological tissue and metals to composites. Our instruments are used for research by the world's most advanced scientific organisations and companies. Each of our instruments are designed and manufactured in-house by our team of highly experienced electronics, software and mechanical design engineers. We design and develop solutions for sample characterisation by collaborating with the best scientists in the world. Will you be next?

Linkam products are constantly being improved, hence specifications are subject to change without notice.
TASC products are a family of techniques developed by Prof. Mike Reading (Cyversa) and Linkam.



 www.linkam.co.uk

 +44 (0)1737 363476

 info@linkam.co.uk